



Federal Aviation Administration

With recommendations for improvement by AvioConsult - Harry Horlings, graduate of the USAF Test Pilot School.

Disagree?

Please refer to the formal FAA and University references listed on the downloads page of www.avioconsult.com, or consult an experimental test pilot or flight test engineer.

Flying Light Twins Safely



Note: The graphics and some of the material in this document have been modified from the original printed version.

Introduction

The major difference between flying a light twin and a single-engine airplane is knowing how to manage the flight if one engine loses power. Safe flight with one engine inoperative (OEI) requires an understanding of the basic aerodynamics involved as well as proficiency in single-engine flight. This booklet deals extensively with the numerous aspects of OEI flight. You must remember, however, not to place undue emphasis on mastery of OEI flight as the sole key to flying light twins safely.

The Normal Takeoff

For normal takeoff planning, use the manufacturer's recommended rotation speed (V_r) or lift-off speed (V_{lof}). If no such speeds are published, use a minimum of minimum control speed (V_{mc}) plus 5 knots for V_r . As a rule, light twins should not be airborne before reaching V_{mc} .

Recommend using V_{mca} , to distinguish between Visual Met. Conditions and V_{mcl} and V_{mcg} .

Way too low for wings level. Use at least $V_{mc} + 10$.

View video on YouTube/AvioConsult channel to see what happens: <http://youtu.be/Wbu6X0hSnBY>

After lift-off, the next consideration is to gain altitude as rapidly as practicable. After leaving the ground, altitude gain is more important than achieving an en route climb airspeed. Allow the airplane to accelerate in a shallow climb to attain V_y , the best rate of climb speed when both engines are operating. Maintain V_y until a safe single-engine maneuvering altitude, typically at least 400 feet above ground level (AGL), has been achieved. (If V_y would result in a pitch attitude of more than 15 degrees, consider limiting the initial pitch attitude to 15 degrees to minimize control difficulty if an engine is lost.) A transition to an en route climb can then be made as climb power is set.

Landing gear retraction should occur after a positive rate of climb is established, but not before reaching a point from which a safe landing can no longer be made on the runway or overrun remaining.

The Critical Engine

The critical engine is the engine whose failure would most adversely affect the airplane's performance or handling qualities. On twin-engine airplanes with both engines turning in a conventional, clockwise rotation (viewed from the cockpit), the left engine is critical. At cruise airspeed, the thrust line of each engine may be considered to be the propeller hub.

At low airspeeds and high angles of attack, the effective thrust centerline shifts to the right on each engine because the descending propeller blades produce more thrust than the ascending blades (P-factor). The more power, the greater the effect.

The right shifting thrust of the right engine operates at a greater moment arm (that is, distance from the airplane's center of gravity) than the left engine. Thus, the right engine produces the greatest yawing moment and requires the most rudder to counteract the adverse yaw.

P-vector. (the arrow, with magnitude and direction). P-vector is a 'factor' to consider.

results in

Critical Engine & V_{mc}

- Critical engine is the engine whose failure would have the most adverse impact on the handling (control) qualities of the airplane.
- With props rotating clockwise, the descending blade on the left engine is close to the centerline. Right engine descending blade is farther from the centerline, which creates greater yawing force if left engine fails. Left engine is therefore critical.
- V_{mc} is the minimum flight speed at which the aircraft is directionally controllable with a bank of no more than 5° when the critical engine is inoperative (windmilling) and the remaining engine is operating at takeoff power.
- At any airspeed below V_{mc} , there may not be sufficient rudder authority to counteract the yawing movement and maintain directional control of the airplane.

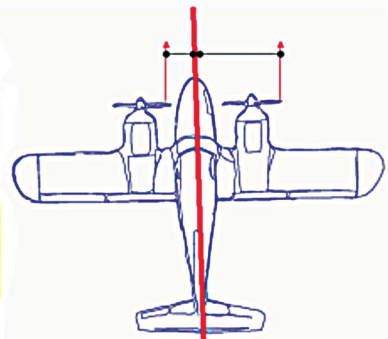

moment. The force is the same.

, or while not maintaining the 5° favorable bank angle,

V_{mc} is the minimum airspeed at which the aircraft can maintain straight flight while maintaining a bank angle of 5° away from the inoperative critical engine and the remaining engine is operating at maximum power. V_{mc} after failure of the other engine will be a little lower, safer.

IMPORTANT NOTE

The Vmc published in the AFM is the worst case Vmc, which is determined when the critical engine is inoperative, besides other configuration items being at their worst case values, such as low weight and aft cg. This one Vmc is to be observed after failure of either engine, not only after failure of the critical engine. There is also only one engine emergency procedure for failure of either engine.

So, pilots do not need to know about the critical engine, only testpilots need to know for determining the highest Vmc. Analyzing the criticality of the failing engine in the cockpit might delay the appropriate actions by the pilot, resulting in a loss of control in flight (and CFIT).

Vmc after failure of either engine is the same. Both engines are equally critical.

Some twins of more recent design use a counter-rotating right engine to eliminate the critical engine. Handling qualities are the same, regardless of which engine fails on one of these airplanes.

FLY

Thrust Asymmetry

Loss of power on one engine creates both control and performance problems. Control problems include the need to counteract the following:

- **Yaw.** Loss of power on one engine creates yaw due to asymmetrical thrust.
- **Roll.** Loss of power on one engine eliminates propeller blast over the wing. This elimination affects the lift distribution over the wing, causing a roll toward the inoperative engine.

limitations

Pilots

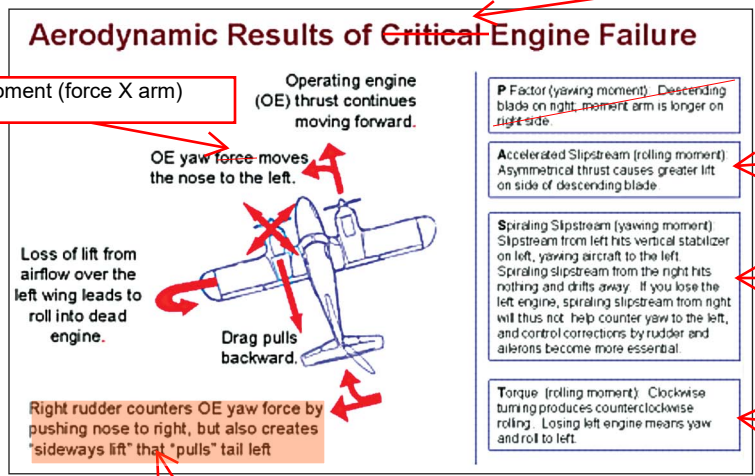

Applies also to other engine failure

The yaw and roll forces must be counteracted by a combination of rudder and aileron.

Reduced slipstream failed engine reduces (propulsive) lift

?? This text is not right. From left? That engine is inop. Only while sideslipping a slipstream might have effect.

?? Torque forces act on the engine wing mounts. May be just a little effect on the rolling moments.

Zero Sideslip

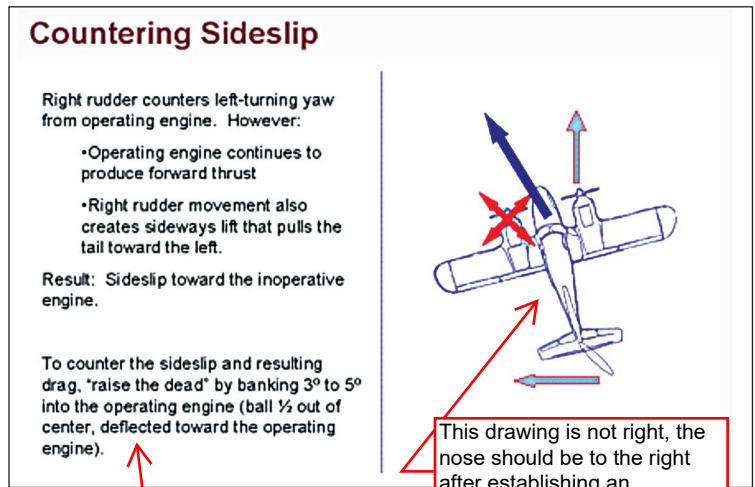

Good!

This drawing is not right, the nose should be to the right after establishing an equilibrium while OEI.

Recommend to use Figures out of FAA-H-8083 Chapter 12.

In OEI flight, no instrument directly tells the pilot that the airplane is being flown at zero sideslip. The aircraft must be placed in a predetermined attitude of bank and ball deflection. In the absence of a yaw string, the suggested zero sideslip configuration at best single-engine rate of climb airspeed (V_{yse}) for most light twins is approximately two to three degrees of bank toward the operating engine, with the ball displaced about one-half of its diameter from center, also toward the operating engine.

as should be presented in the legend of the OEI climb performance graphs.

OEI flight with the ball centered and the remaining engine providing any appreciable power is *never* correct due to the sideslip generated. Aircraft Flight Manual/Pilot's Operating Handbook (AFM/POH) performance figures for OEI flight were determined at zero sideslip, although that fact may not be expressly stated in the manual or handbook.

Key Airspeeds for Single-Engine Operations

Minimum Control Speed

V_{mc} is designated by a red radial line near the low speed end on most airspeed indicators. Under the small airplane certification regulations currently in effect, the flight test pilot must be able to accomplish the following:

- Stop the turn that results when the critical engine is suddenly made inoperative within 20 degrees of the original heading, using maximum rudder deflection and a ~~maximum of 5 degrees~~ angle of bank into the operative engine.
- Thereafter, maintain straight flight with ~~no more than a 5-degree angle of bank~~ away from the inoperative engine.

the bank angle for zero sideslip, which should not be

Under the current 14 CFR Part 23 small airplane certification rules, V_{mc} is determined with the following factors:

- Maximum available takeoff power.
- Propeller windmilling in takeoff pitch (or feathered, if the aircraft is equipped with autofeather).
- Most unfavorable (aft-most) center of gravity and ~~maximum takeoff weight (or any lesser weight necessary to show V_{mc})~~ Is only for test pilots to evaluate the airplane in case $V_{mc} < V_s$.
- Landing gear retracted.
- Wing and cowl flaps in the takeoff position.
- Trimmed for takeoff.
- Airborne, out-of-ground effect.

Must be: minimum weight. V_{mc} is higher at low weight (effect of weight and banking on the side forces), The worst case - highest V_{mc} - is to be published in the AFM and designated by a red radial line on the airspeed indicator. Low weight is worst case. 'Maximum' weight is for determining the worst case stall speed V_s .

The results are then plotted for a variety of altitudes and extrapolated to a single, sea-level value. The twin that you are flying may or may not have been certificated under exactly these rules—the AFM/POH will state the certification basis.

varying with ...

Good, but this paragraph was regrettably not understood by the many mishap pilots.

V_{mc} varies with each of the above factors. The V_{mc} noted in practice or demonstration, or in actual OEI operation, could be less or even greater than the published value. With other factors constant, V_{mc} is highly sensitive to bank angle. It is reduced significantly with increases in bank angle, and it increases significantly as the wings approach level. Tests have shown that V_{mc} may increase more than 3 knots for each degree of bank less than 5 degrees. Loss of directional control may be experienced at speeds almost 20 knots above published V_{mc} when the wings are held level.

, as is the sideslip angle.

or are into the inop. engine

...increasing the sideslip until the fin stalls.

... the actual Vmc, i.e. the Vmc that the pilot would experience in-flight.

Control vs. Performance

Conditions that lower Vmc INCREASE control but DECREASE performance:

- CG forward – longer arm increases rudder effectiveness.
- Density altitude – high DA decreases engine power & thrust.
- Engine power reduction on OE decreases asymmetric thrust.
- Feathering failed engine reduces drag and yaw.
- Maximum takeoff weight helps resist yaw.
- Zero sideslip can reduce Vmc by 3 knots per degree of bank angle.

No, it is the other way around. Vmc is measured at the bank angle for which the sideslip is zero. Any deviation from this bank angle increases sideslip, hence drag. See previous page for effect on Vmc.

Flight test pilots' determination of Vmc in airplane certification is solely concerned with the minimum speed for directional control under one very specific set of circumstances. Vmc has nothing to do with climb performance, nor is it the optimum airplane attitude, bank angle, ball position, or configuration for best climb performance. Many light twins will not maintain level flight near Vmc with OEI.

- the worst case circumstances that a pilot will ever experience in-flight (provided the favorable bank angle is maintained and rudder is adequate to counter yaw).

??
The bank angle for zero sideslip (min. drag) is the bank angle used to determine Vmc.
Quote of Dr. Jan Roskam, KU, in his Airplane Design series of books: "Control and performance are tied together by bank angle".

Best Single-Engine Angle of Climb Airspeed

Best single-engine angle of climb airspeed (Vxse) is used only to clear obstructions during OEI initial climbout because it gives the greatest altitude gain per unit of horizontal travel. Vxse is invariably a slower speed than Vyse and may be just a very few knots above Vmc. Even at Vxse, the climb gradient will be paltry.

if a small bank angle is not maintained

Best Single-Engine Rate of Climb Airspeed

Best single-engine rate of climb airspeed (Vyse) is designated by a blue radial line on most airspeed indicators. It delivers the greatest gain in altitude per unit of time, with the airplane in the following configuration:

- Inoperative engine propeller in the minimum drag position (feathered).
- Maximum power on the remaining (operative) engine.
- Landing gear retracted.
- Wing flaps in the most favorable (best lift/drag ratio) position.
- Cowl flaps as required for engine cooling.
- Airplane flown at zero sideslip, i.e. with a small favorable bank angle, meaning straight flight!

, i.e. bank angle away from the bank angle presented in the legend of OEI performance data,

Drag from a windmilling propeller, extended landing gear, flaps extended beyond optimum, or any sideslip will reduce or even eliminate any modest single-engine performance that may exist. Turbulence and maneuvering of the airplane will further erode performance. When operating above the airplane's single-engine ceiling, Vyse will deliver the least possible rate of sink (driftdown).

and lead to loss of control because of increasing actual Vmc.
Least ROD is at Vxse. Vyse will deliver max. range.

Safe, Intentional OEI Speed

Safe single-engine speed (Vsse) is the minimum speed at which intentional engine failures are to be performed. This speed is selected by the manufacturer to reduce the accident potential from loss of control due to simulated engine failures at inordinately slow airspeeds. No intentional engine failure in flight should ever be performed below Vsse.

Good!

Single-Engine Runway Requirements

Consult the performance charts in the AFM/POH. The newer manuals show the following requirements:

Accelerate-Stop Distance

Accelerate-stop distance is the runway required to accelerate to either V_r or V_{lof} (as specified by the manufacturer) and, assuming an engine failure at that instant, to bring the airplane to a complete stop.

Accelerate-Go Distance

Accelerate-go distance is the distance required to accelerate to either V_r or V_{lof} (as specified by the manufacturer) and, assuming an engine failure at that instant, to continue the takeoff on the remaining engine and climb to a height of 50 feet.

but with adequate pilot action delays.

Always remember that these figures were determined under ideal flight test circumstances. It is unlikely that they could be duplicated under real-world conditions. There is no guarantee that under all conditions a light twin would be capable of continuing a takeoff and climbing out after an engine failure. Before taking the runway, you should know if the airplane could reasonably be expected to continue its climb following an engine failure.

Single-Engine Climb Performance

and on the remaining drag due to countering the asymmetrical thrust.

Climb performance depends on an excess of thrust (power) over that required for level flight. Loss of power on one engine represents a 50-percent loss of thrust, but it often results in an 80- to 90-percent loss of climb performance and sometimes even more.

The current 14 CFR Part 23 single-engine climb performance requirements for reciprocating-engine twins are as follows:

- **More than 6,000 pounds maximum certificated takeoff weight and/or V_{so} of more than 61 knots.** The single-engine rate of climb in feet per minute at 5,000 mean sea level (MSL) must be equal to at least $.027 V_{so}^2$. For twins type-certificated on February 4, 1991, or thereafter, the single-engine climb requirement is expressed in terms of a climb gradient, 1.5 percent.
- **6,000 pounds or less maximum certificated takeoff weight and V_{so} of 61 knots or less.** The single-engine rate of climb or climb gradient at 5,000 MSL must simply be determined. The rate of climb could be a negative number. There is no requirement for a positive single-engine rate of climb at 5,000 feet or any other altitude.

Rate of climb is the altitude gain per unit of time, and climb gradient is the actual measure of altitude gained per 100 feet of horizontal travel, expressed as a percentage. An altitude gain of 1.5 feet per 100 feet of horizontal travel is a climb gradient of 1.5 percent.

Regarding climb performance, the light twin with OEI will perform marginally at best and may not be capable of climbing at all under existing conditions. There is no requirement that a light twin in the takeoff or landing configuration must be able to maintain altitude, even at sea level, with OEI.

if a small bank angle is maintained as should be published with OEI climb performance data in AFM/POH.

Airspeed

Best single-engine climb rate is found at Vyse with maximum available power and minimum drag. After the flaps and landing gear have been retracted and the propeller of the inoperative engine feathered, a key element in extracting best climb performance is minimizing sideslip by maintaining straight flight and a small bank angle away from the inoperative engine until a safe altitude is reached.

Single-Engine Ceilings

The single-engine service ceiling is the altitude at which twins can no longer climb at 50 feet per minute in smooth air, with one engine feathered, at maximum certificated takeoff weight. The single-engine absolute ceiling is where the rate of climb is zero. inoperative, and its propeller

The single-engine service ceiling should be reviewed before each flight to determine if the airplane, as loaded, can maintain appropriate minimum IFR or VFR altitudes following the loss of an engine.

Engine Failure After Lift-off

The manufacturer's recommended procedures for an engine failure shortly after lift-off can be found in the AFM/ POH for the specific make and model of airplane. Certain basic procedures, however, follow below. Complete failure of an engine after lift-off can be broadly categorized into one of the following three scenarios.

Landing Gear Down

If the failure occurs before selecting the gear to the "up" position, it is recommended that the pilot close both throttles and land on the runway or overrun remaining.

Landing Gear Selected Up, OEI Climb Performance Inadequate

and control

When operating near or above the single-engine ceiling and an engine failure is experienced shortly after lift-off, a landing must be accomplished on essentially whatever lies ahead. The greatest hazard in an OEI takeoff is attempting to fly when it is not within the performance capability of the airplane to do so.

A recent study revealed a very high success rate for off-airport engine-inoperative landings when the airplane was landed under control. The same study also revealed a very high fatality rate in stall-spin accidents when the pilot attempted flight beyond the performance capability of the airplane.

and control

These were not stall-spin accidents, but loss of control +cft because pilots didn't maintain straight flight while banking the favorable bank angle.

Landing Gear Selected Up, OEI Climb Performance Adequate

If the single-engine rate of climb performance is sufficient to continue flight, four areas of concern must be addressed. In order of precedence, they include the following:

- **Control.** The rudder and aileron should be used, aggressively if necessary, to counteract the yaw and rolling tendencies. At least 5 degrees, and up to 10 degrees, angle of bank should be used to maintain directional control. The pitch attitude for Vyse should be assumed.
- **Configure.** The actions listed in the "Engine Failure After Takeoff" checklist in this pamphlet should be promptly executed to configure the airplane for climb with minimum drag.

Vmc not only applies during takeoff, but also during turns at low speed for returning to downwind, base leg or during the final turn for landing (when the thrust is increased to max.).

If a turn is necessary, climb straight to an altitude first where some altitude can be sacrificed for a safe turn while temporarily reducing asymmetrical thrust a little (Vmc will be lower).

No, definitely not if IAS is low and asymmetrical thrust is high! At bank angles greater than 5°, sideslip increases and the fin might stall after which control will be lost, and CFIT is not avoidable. Before on page 3, max. 5° is mentioned!

away from the inoperative engine

straight flight. Published Vmc applies only to straight flight while banking a few degrees away from the inoperative engine (FAR 23.149).

- Climb.** Maintain Vyse. ~~Reduce~~ the bank angle to that of zero sideslip. In the absence of specific AFM/POH recommendations, a bank of approximately 2 to 3 degrees and a ball displacement of about one-half of the ball diameter from center should be made. The bank angle and ball displacement will both be toward the operative engine.

Maintain straight flight and

(usually 2 - 3° away from the inop engine) and climb to a safe altitude.

this is for Vmc, not the higher Vyse; displacement might have to be smaller.
- Checklist.** On reaching 400 feet AGL, refer to the printed checklist. Review the Engine Failure After Takeoff Checklist items. If workload permits, then accomplish the "Securing Failed Engine" checklist items to turn off systems and accessories no longer required.

Engine Failure During Cruise

An in-flight engine failure generally allows more time for diagnosis of the problem with a view toward remedying the situation, if possible. A logical and orderly check of gauges, switches, and systems may rectify the problem without resorting to engine feathering. As with any single-engine operation, declare an emergency with Air Traffic Control.

Engine Failure After Takeoff Checklist

Wrong checklist?

Component	Action
Airspeed	Maintain Vyse
Mixtures	Rich
Props	High RPM
Throttles	Full power
Flaps	Retracted
Landing gear	Retracted
Identify	Which engine failed
Verify	Close inop engine throttle
Inop engine prop	Feather

For takeoff checklist: Strongly recommend to add in Takeoff Checklist, preferably as step 2, following rudder to counter yaw: Bank 5° into good engine (same side as rudder). If not and at low altitude, the other steps are not possible anymore (already CFIT).

RPM = rotations per minute.

with one important exception: never increase asymmetrical thrust to max. before straight flight with a small favorable bank angle away from the inoperative engine is achieved, or LOC and CFIT will occur.

Engine Inoperative Approach and Landing

The OEI approach and landing should be flown as close as possible to a normal approach and landing in terms of key positions, altitudes, and airspeeds. The approach and landing may be conducted with no more than partial flaps, or full flaps may be selected when on short final with the landing absolutely assured. Large or sudden applications in power are to be avoided. The airplane will float somewhat in the roundout for landing without the drag of both windmilling propellers, particularly if the flaps have been only partially extended.

It is a lot safer to fly a long straight-in approach.

Every effort should be made to execute the approach and landing successfully the first time. Above all, avoid a single-engine go-around. From a landing configuration with any degree of extended flaps, the light twin will need an excessive amount of altitude to make the transition from a descent to a climb with gear and flaps retracted.

?

Minimum Control Airspeed (Vmc) Demonstration

For a Vmc demonstration, an altitude should be selected that will allow completion of the maneuver at least 3,000 ft AGL. The following scenario assumes a conventional light twin with noncounter-rotating engines, where the left engine is critical.

Please also demo the failure of the non-critical engine! Then Vmc is only a little lower, often nearly the same!

to the thrust for zero drag (refer to AFM/POH). Idle increases asymmetrical drag and therewith actual Vmc.

while maintaining heading with rudder and bank angle with ailerons.

Consider demo Vmc with wings level first, because this (actual) Vmc is 8 to 10 kt higher than the red-lined Vmc. Record ROD/ROC.

With the landing gear retracted and the flaps set to the normal takeoff position, the airplane should be slowed to approximately 10 knots above Vsse or Vyse (whichever is higher) and trimmed for takeoff. An entry heading should be selected and high RPM set on both propeller controls. Power on the left engine should be throttled back to idle and power on the right engine advanced to the takeoff setting. The pilot must be alert for the stall warning horn, if the aircraft is so equipped, or watch for the stall warning light. The left yawing and rolling moment of the asymmetrical thrust is counteracted primarily with right rudder. A bank angle of 5 degrees (a right bank angle, in this case) should also be established to assist with directional control.

reduce both drag and actual Vmc during straight flight.

While maintaining entry heading, the pitch attitude is slowly increased to decelerate at a rate of 1 knot per second (no faster). As the airplane slows and control effectiveness decays, the increasing yawing tendency should be counteracted with additional rudder pressure. Aileron displacement will also increase to maintain 5 degrees of bank. An airspeed is soon reached in which full right rudder travel and a 5-degree bank can no longer counteract the asymmetrical thrust, and the airplane will begin to yaw uncontrollably to the left dead engine side.

slowly, though, but

The moment the pilot first recognizes the uncontrollable yaw or experiences any symptom associated with a stall, recovery should be initiated by simultaneously reducing power sufficiently on the operating engine while decreasing the pitch attitude as necessary to stop the yaw. Recovery is made with a minimum loss of altitude to straight flight on the entry heading at Vsse or Vyse, as symmetrical power is set. The recovery should not be accomplished by increasing power on the windmilling engine alone.

With normally aspirated engines, Vmc decreases with altitude as reduced power available results in less asymmetrical thrust. Stalling speed (Vs), however, remains the same. Except for a few models, published Vmc is almost always higher than Vs. At sea level, there is usually a margin of several knots between Vmc and Vs, but the margin decreases with altitude and, at some altitude, Vmc and Vs are the same.

Remember, at altitude, the wings level Vmc is also higher than published and indicated Vmc.

Where Vs is encountered at or before Vmc, the departure from controlled flight may be quite sudden, with strong yawing and rolling (spinning) tendencies toward the idle engine. Therefore, during a Vmc demonstration, if there is any indication of an impending stall, such as a stall warning light or horn, airframe or elevator buffet, or rapid decay of control effectiveness, the maneuver should be terminated immediately. Reduce the angle of attack as the throttle is retarded and return the aircraft to entry airspeed. Light twins are not approved for spins and their spin recovery characteristics are generally quite poor.

by keeping the wings level, or by idling engine, rather than at thrust for zero drag, or

When stall indications are reached before Vmc, the demonstration can still be accomplished by artificially limiting the amount of rudder input to less than full travel. This technique is further described in the FAA's Pilot Practical Test Standards. (http://www.faa.gov/education_research/testing/airmen/test_standards/pilot/)

A Vmc below Vs is safest, is preferable. But actual Vmc might increase above Vs when the bank angle is less than 5° or into the dead engine.

Training Recommendations

Regular training and practice with a qualified instructor are essential for proficiency in any airplane. Here are some safety tips and training recommendations:

- Thoroughly brief simulated engine failures in advance. The pilot should know how such failures will be introduced and what action is expected in response. Unannounced engine failures are suitable only in testing and checking scenarios and when both pilots have agreed to such activity before the flight.
- Low-altitude engine failure is *never* worth the risks involved. Multiengine instructors should approach simulated engine failures below 400 feet AGL with extreme caution, and failures below 200 feet AGL should be reserved for simulators and training devices.

- All simulated engine failures below 3,000 AGL should be accomplished by smoothly retarding the throttle.
- Recognize that aircraft systems knowledge is critically important. Practice systems failures too, including partial panel instrument training.
- Occasionally practice OEI flight with a yaw string to observe bank angle and ball position for zero sideslip, particularly at Vyse.
- Do not alter the airplane configuration on the runway after landing unless there is a clear operational need to do so. A striking number of inadvertent landing gear retractions have occurred when the pilot intended to retract the flaps.

Summary

Know the key airspeeds for your airplane and when to fly them. Become thoroughly familiar with the AFM/POH recommended procedures and the checklist, particularly the memory items.

In OEI flight, know the following different bank angles for your airplane and when to fly them:

>5° is very dangerous at airspeeds as low as Vmc and high thrust (fin stall).

- Five ~~to~~ 10 degrees of bank to initially assist the rudder in maintaining directional control in the event of an engine failure, as the pitch attitude for Vyse is established.
- ~~A 5-degree bank during the Vmc demonstration is required for the practical test for a multiengine class rating.~~ Straight flight with
- Approximately 2 to 3 degrees of bank with the ball slightly displaced toward the operative engine to achieve zero sideslip for best climb performance at Vyse.

Know the AFM/POH performance capabilities for your airplane under the proposed flight conditions and factor in significant margins to adjust for real-world performance. Review the following:

- Accelerate-stop distance.
- Accelerate-go distance.
- Single-engine service ceiling.
- Expected OEI rate of climb.
- Terrain or obstacles in the flight path.

straight flight

bank angle for zero sideslip and lowest Vmc and the

Know the following basic OEI emergency procedures common to all conventional light twins:

- **Control.** Maintain ~~directional control~~ with rudder and aileron. Assume the pitch attitude for Vyse.
- **Configure.** Execute the memory items from the “Engine Failure After Takeoff” checklist.
- **Climb.** Assume the bank angle and ball position for zero sideslip and maintain the best climb rate at Vyse.
- **Checklist.** Review and accomplish any remaining checklist items appropriate to the situation.

Finally, practice with a qualified flight instructor at regular intervals. The modern, well-equipped light twin can be a remarkably capable airplane under many circumstances. As with any aircraft, however, it must be flown prudently by a current and competent pilot to achieve the highest level of safety.

Bibliography

- Aarons, Richard N. "Always Leave Yourself An Out," *Business and Commercial Aviation* Vol. 33, No. 1, July 1973.
- Bervin, Lester H. "Engine-Out Characteristics of Multiengine Aircraft," unpublished staff study, Federal Aviation Administration, December 15, 1980.
- Byrington, Melville R., Jr. "Principles to Bank On," *AOPA Air Safety Foundation Flight Instructors' Safety Report* Vol. 15, No. 2, April 1989.
- Byrington, Melville R., Jr. "Engine-Out Booby Traps for Light Twin Pilots," *AOPA Air Safety Foundation Flight Instructors' Safety Report* Vol. 19, No. 2, April 1993.
- Kelly, William P., Jr. "Multi-Engine Stalls," *The Aviation Consumer* Vol. XIX, No. 11, June 1, 1989.
- Kelly, William P., Jr. "When Twins Turn Nasty," *Aviation Safety* (three-part series) Vol. XII, No. 19, October 1, 1992; Vol. 20, October 15, 1992; and Vol. 21, November 1, 1992.
- Newton, Dennis W. "Light-Twin Engine Out Flying," *Business and Commercial Aviation* Vol. 68, No. 11, November 1987.
- Schiff, Barry J. *The Proficient Pilot*. New York: Macmillan, 1985.
- Schiff, Barry J. *The Proficient Pilot, Vol. I*. Newcastle, WA: Aviation Supplies and Academics, Inc., 1997.

About This Series

The purpose of this series of Federal Aviation Administration (FAA) safety publications is to provide the aviation community with safety information that is informative, handy, and easy to review. Many of the publications in this series summarize material published in various FAA advisory circulars, handbooks, other publications, and audiovisual products developed by the FAA and used by the FAA Safety Team (FAASafetyTeam) for educational purposes.

Some of the ideas and materials in this series were developed by the aviation industry. The FAASafetyTeam acknowledges the support of the aviation industry and its various trade and membership groups in the production of this series.

Comments regarding these publications should be e-mailed to ProductManager@FAASafety.gov.

Additional copies of this publication may be downloaded or printed at <http://FAASafety.gov>.